

Rule 24

Towing and Pushing

DOUBLE CLICK ABOVE TO WATCH VIDEO

(a) A power-driven vessel when towing shall exhibit:

(i) instead of the light prescribed in Rule 23(a)(i) or (a)(ii), two masthead lights in a vertical line. When the length of the tow, measuring from the stern of the towing vessel to the after end of the tow exceeds 200 meters, three such lights in a vertical line;

(ii) sidelights;

(iii) a sternlight;

(iv) a towing light in a vertical line above the sternlight;

(v) when the length of the tow exceeds 200 meters, a diamond shape where it can best be seen.

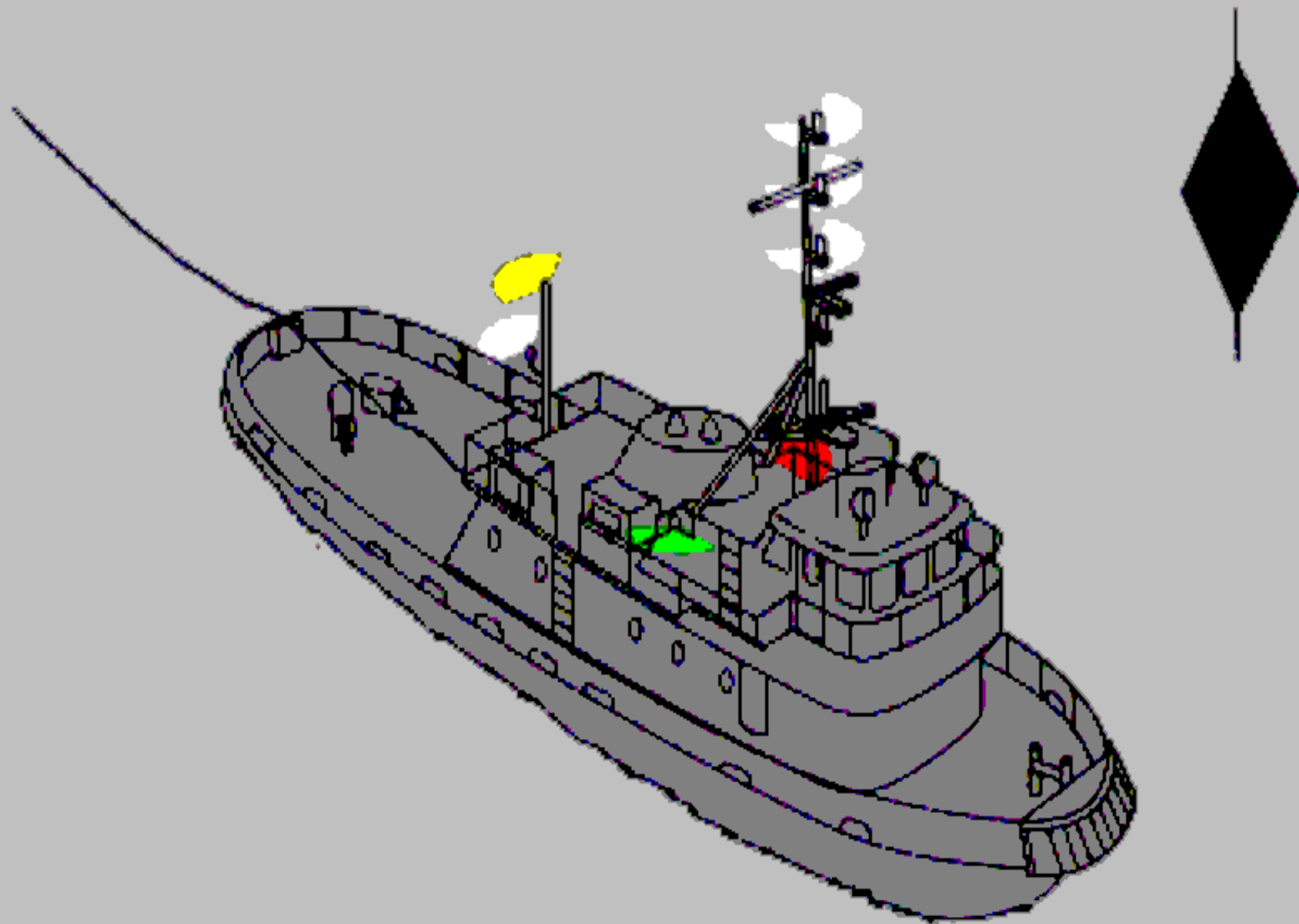



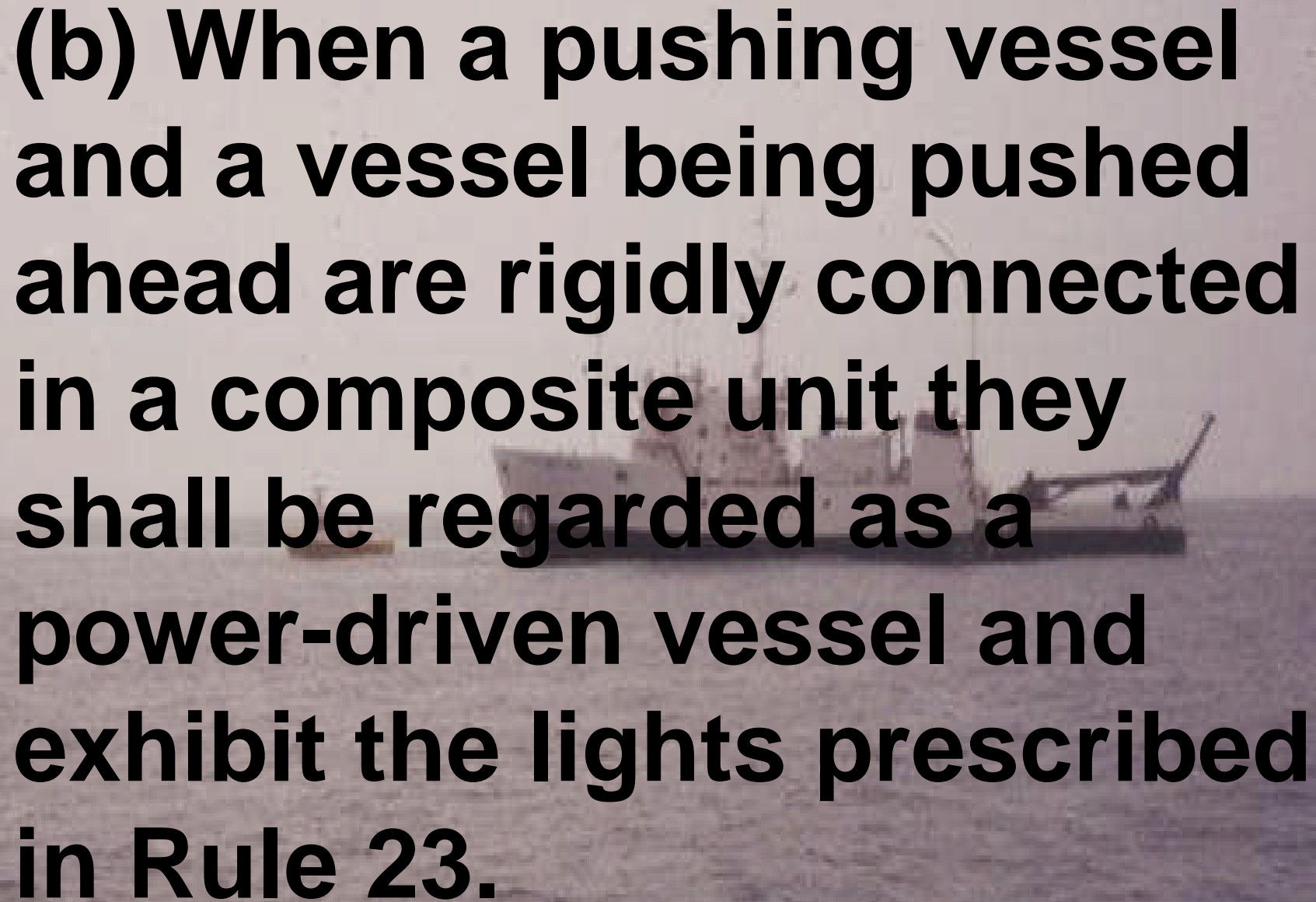

A large industrial vessel, possibly a tugboat or pusher, is shown pushing a barge on a body of water. The vessel is white with a dark hull and has a prominent superstructure. The barge is dark and rectangular. The water is a deep blue-grey color. The background is a hazy, overcast sky.

(b) When a pushing vessel and a vessel being pushed ahead are rigidly connected in a composite unit they shall be regarded as a power-driven vessel and exhibit the lights prescribed in Rule 23.

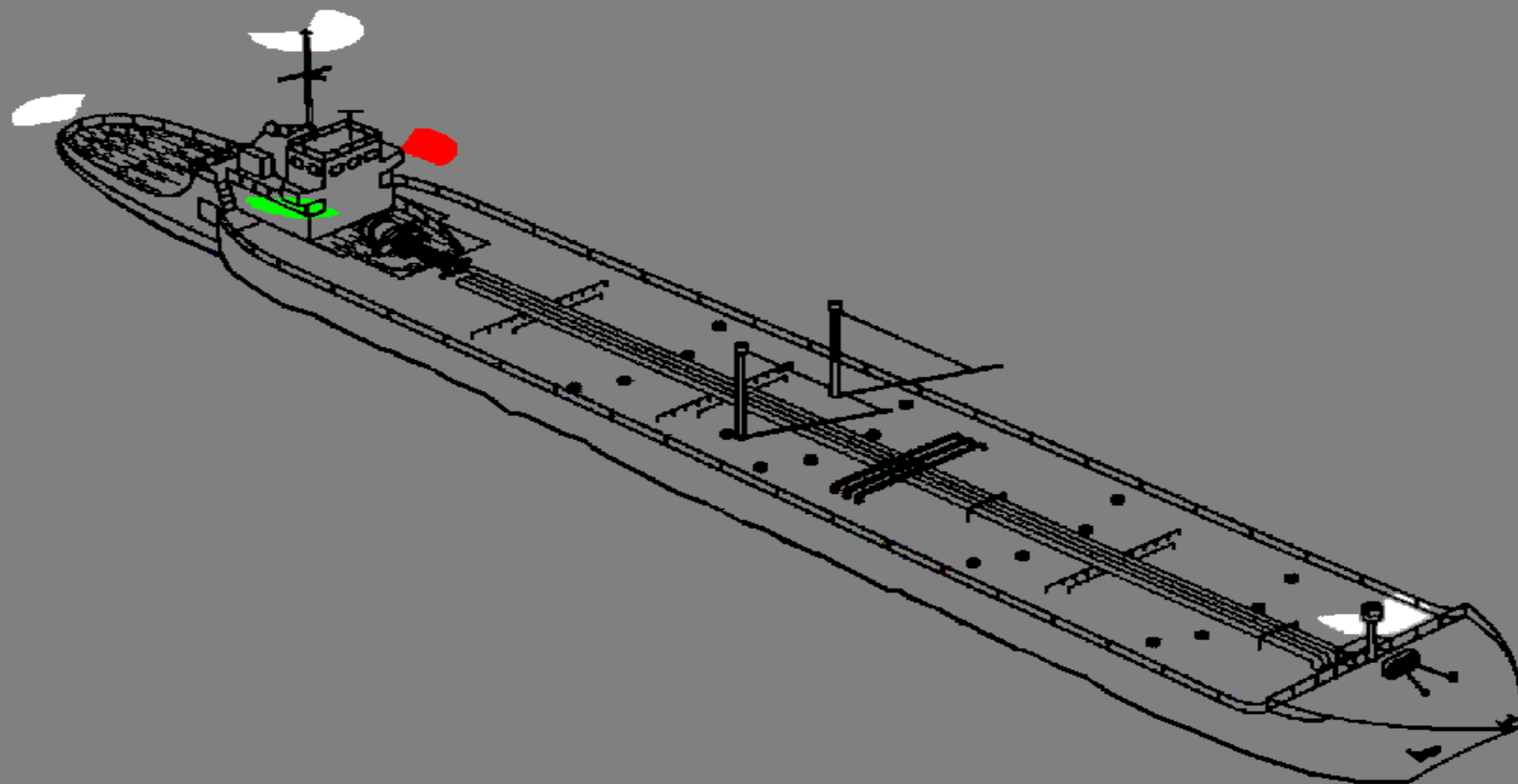



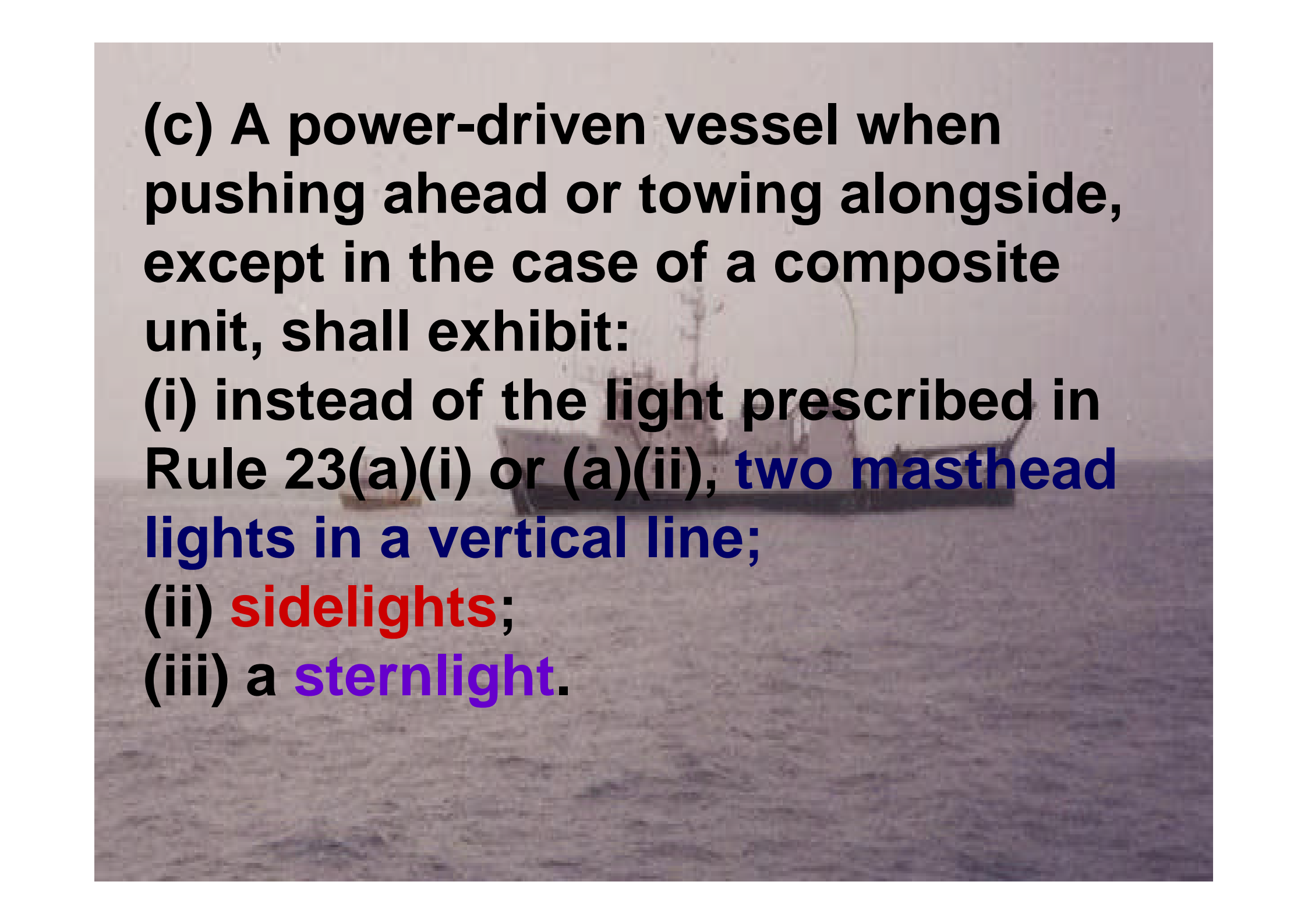

(c) A power-driven vessel when pushing ahead or towing alongside, except in the case of a composite unit, shall exhibit:

(i) instead of the light prescribed in Rule 23(a)(i) or (a)(ii), **two masthead lights in a vertical line;**

(ii) **sidelights;**

(iii) a **sternlight.**

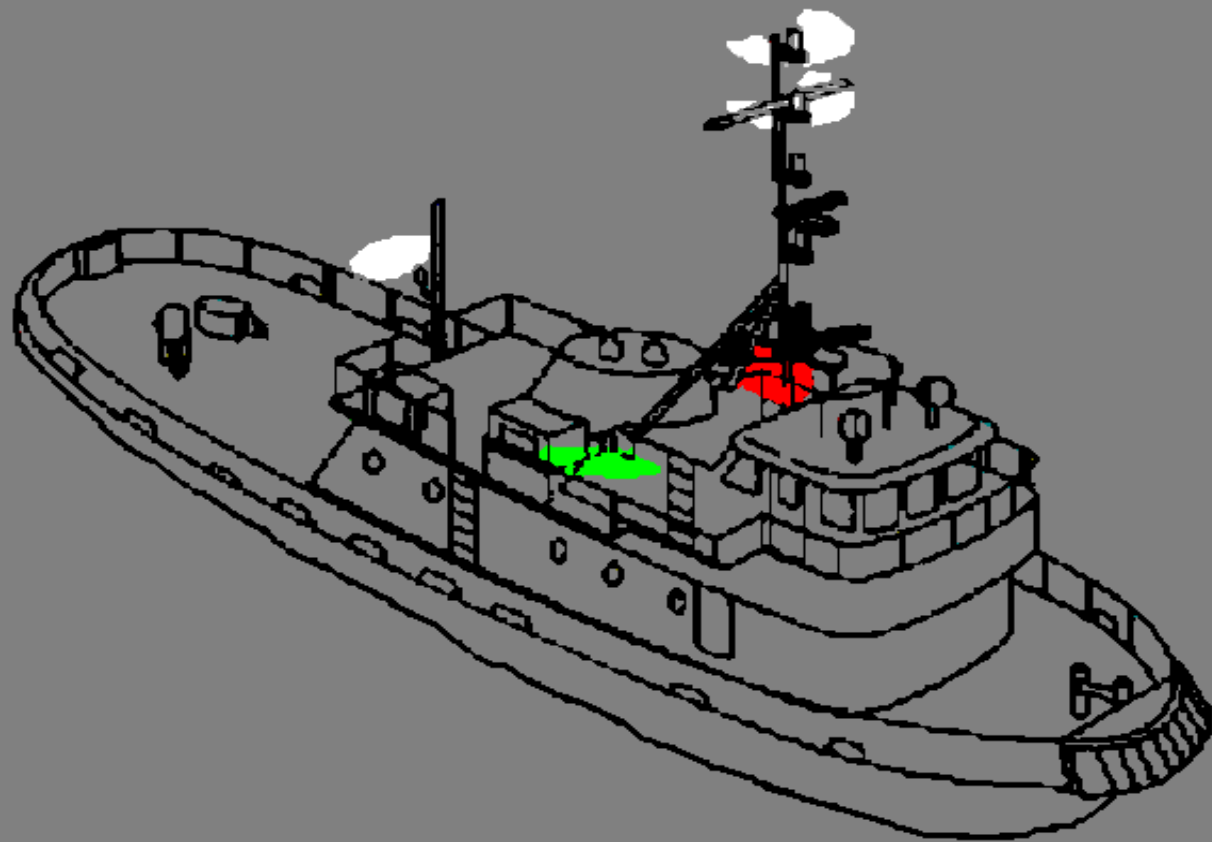

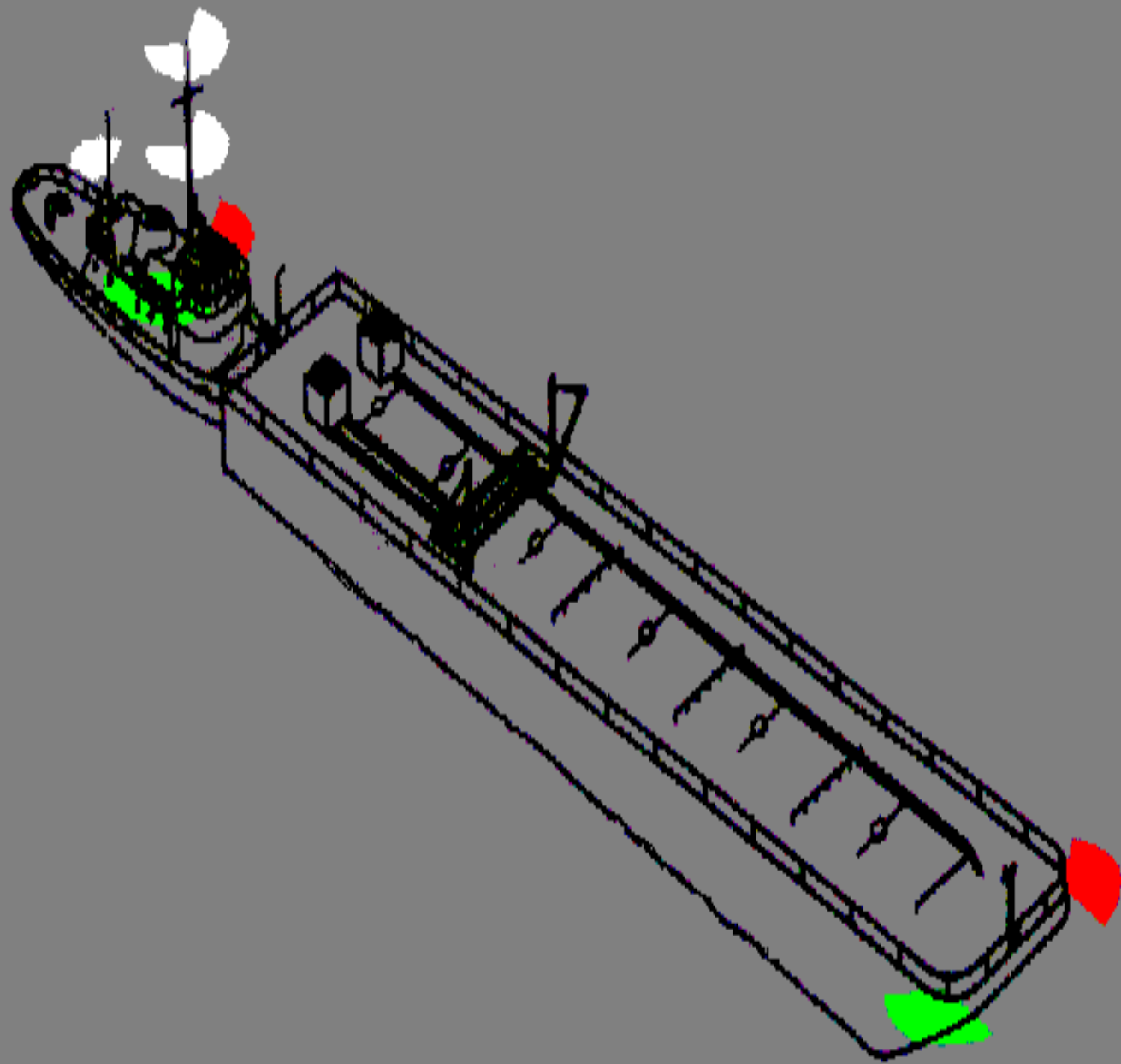

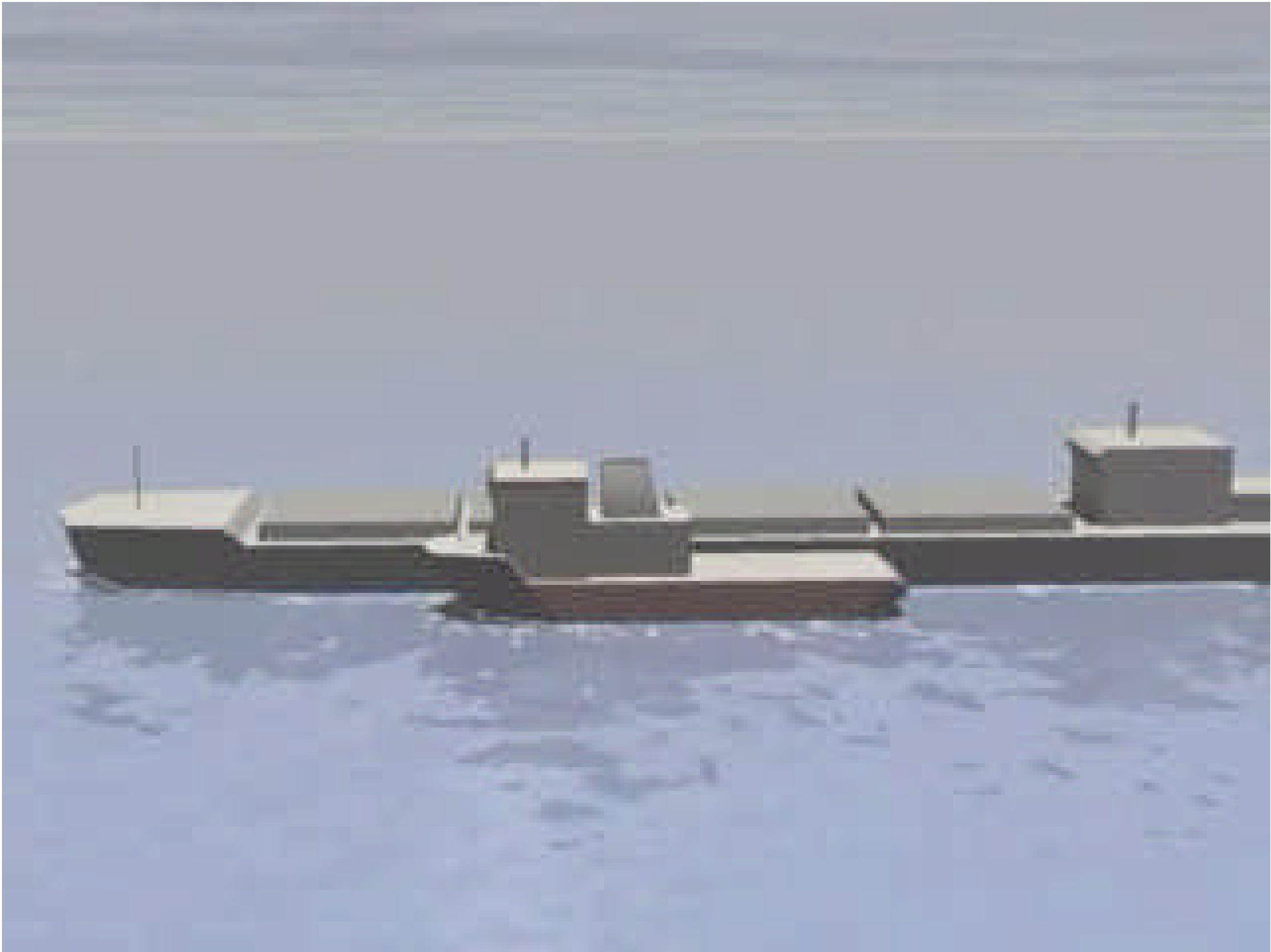

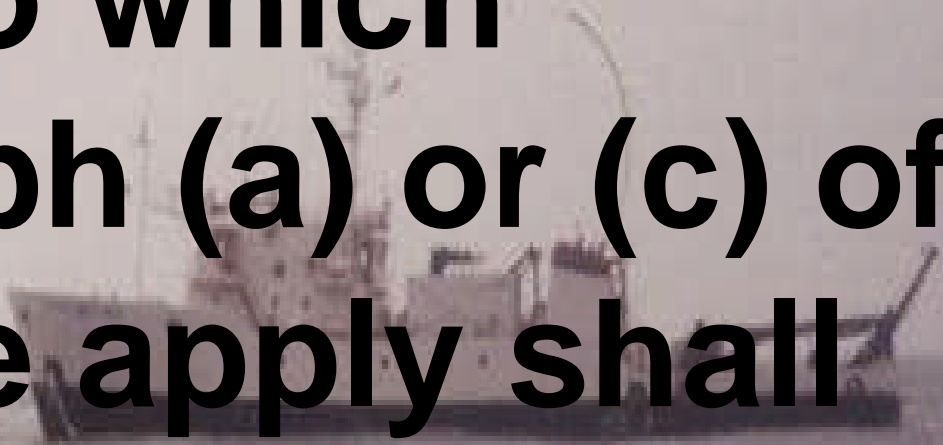
A large, multi-decked power-driven vessel, possibly a tugboat or a small freighter, is seen on the water. The vessel has a white hull and a dark superstructure. It is positioned in the middle ground of the image, slightly to the right of the center. The water is a deep blue-grey color, and the sky is a pale, overcast grey. The overall scene is somewhat hazy, suggesting a misty or overcast day.

(d) A power-driven vessel to which paragraph (a) or (c) of this Rule apply shall also comply with Rule 23(a)(ii).

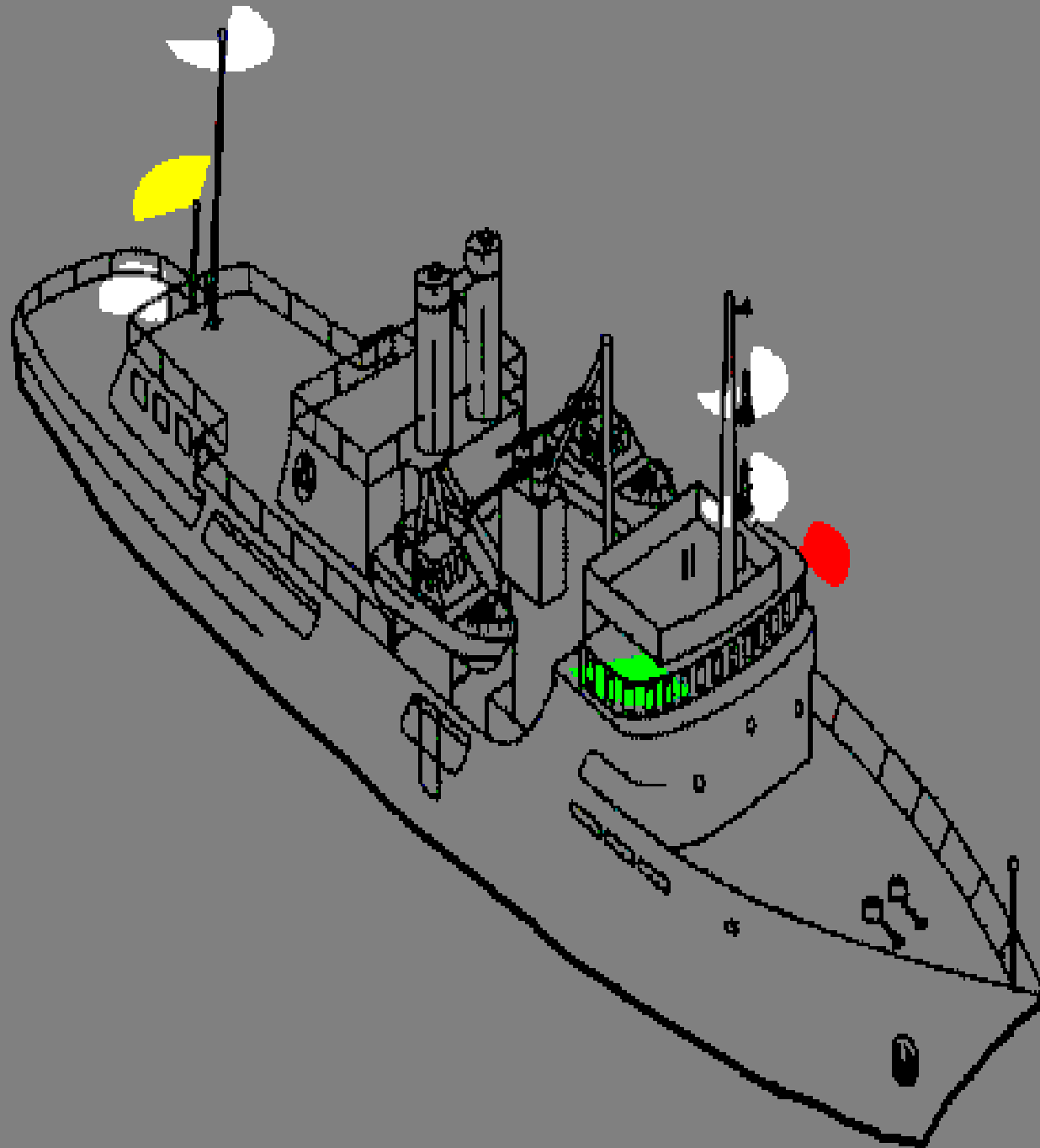

(e) A vessel or object being towed, other than those mentioned in paragraph (g) of this Rule, shall exhibit:

(i) sidelights;

(ii) a sternlight;

(iii) when the length of the tow exceeds 200 meters, a diamond shape where it can best be seen.



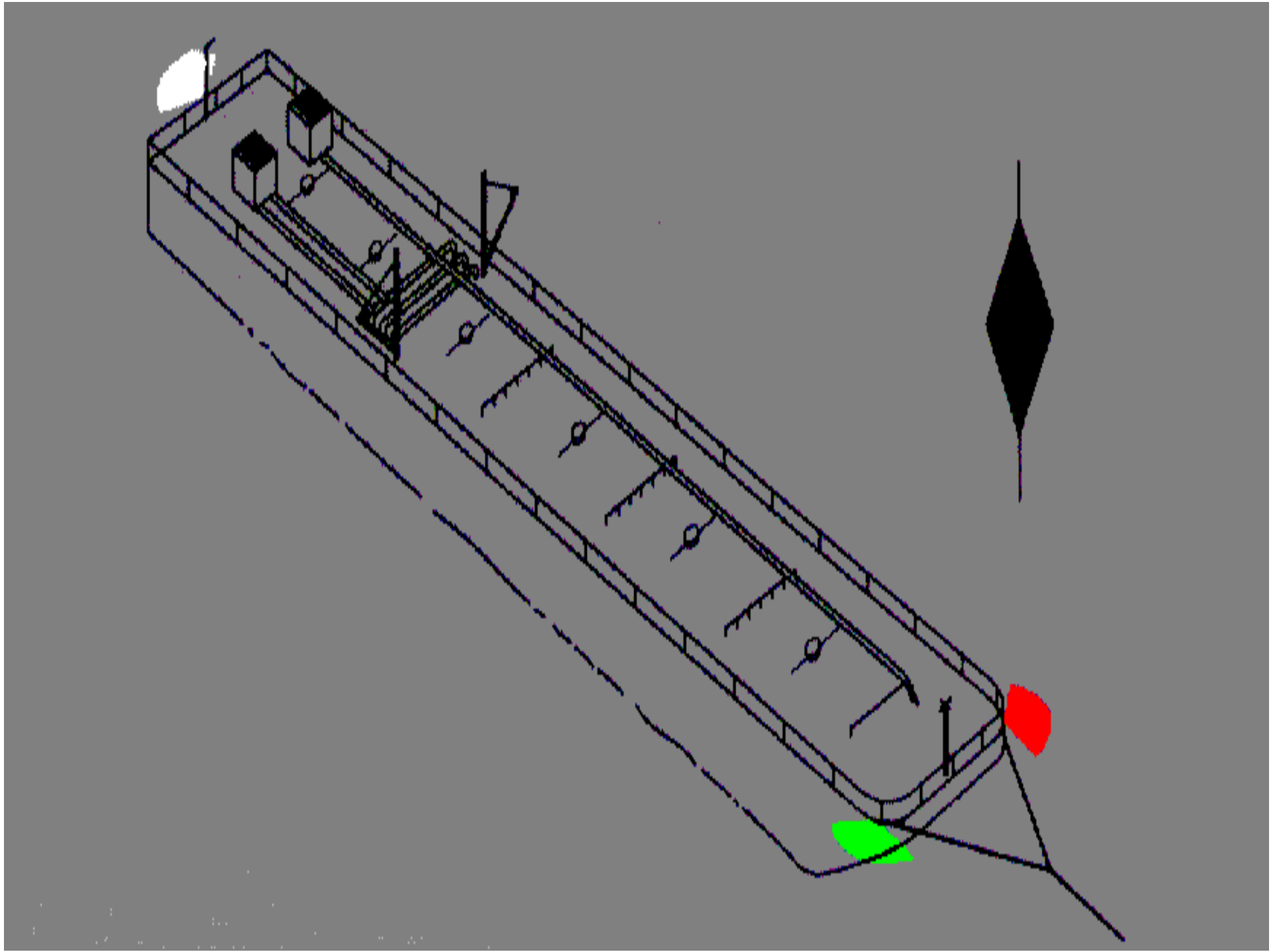

(f) Provided that any number of vessels being towed alongside or pushed in a group shall be lighted as one vessel,

(i) a vessel being pushed ahead, not being part of a composite unit, shall exhibit at the forward end, sidelights;

(ii) a vessel being towed alongside shall exhibit a sternlight and at the forward end, sidelights.

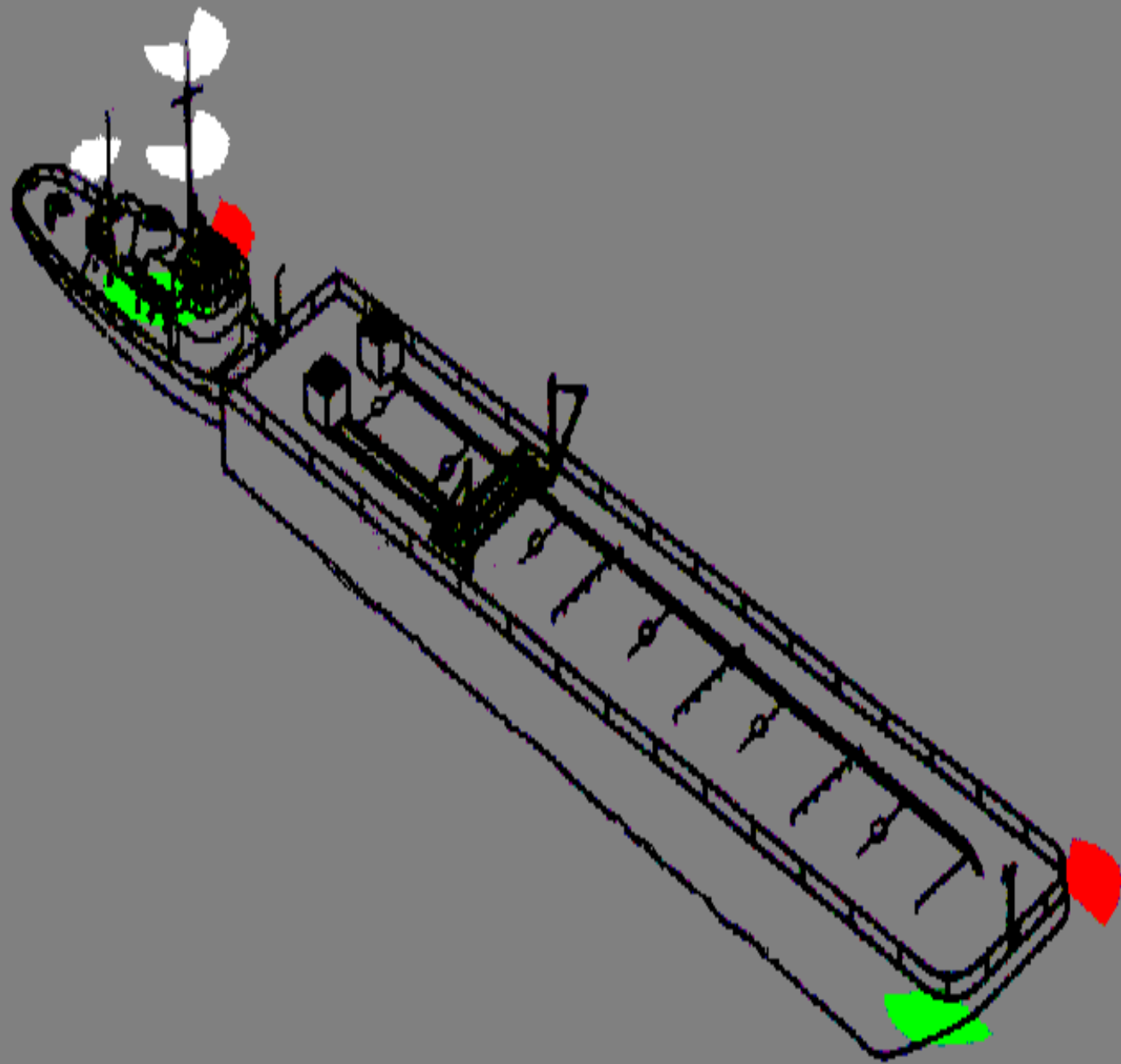

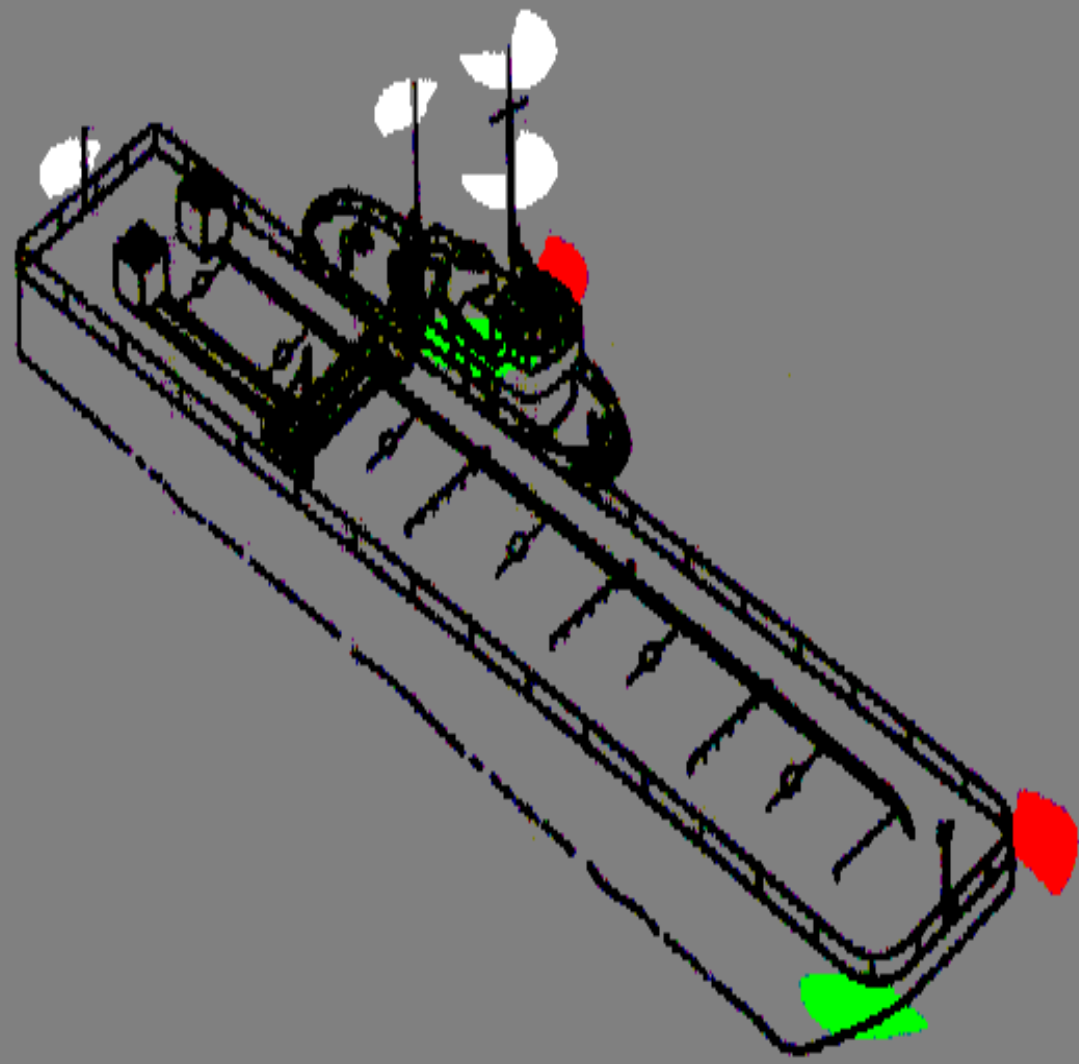

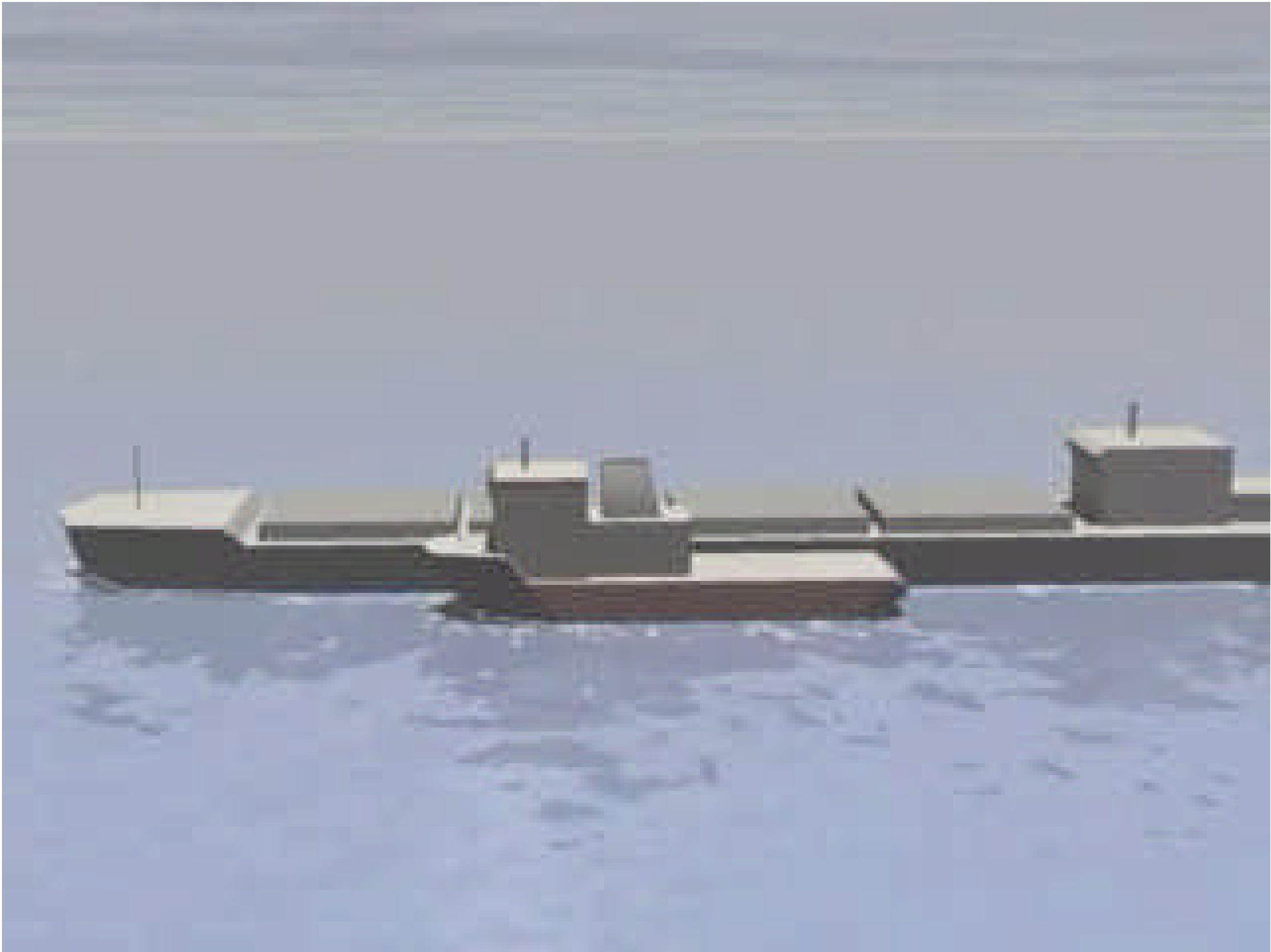

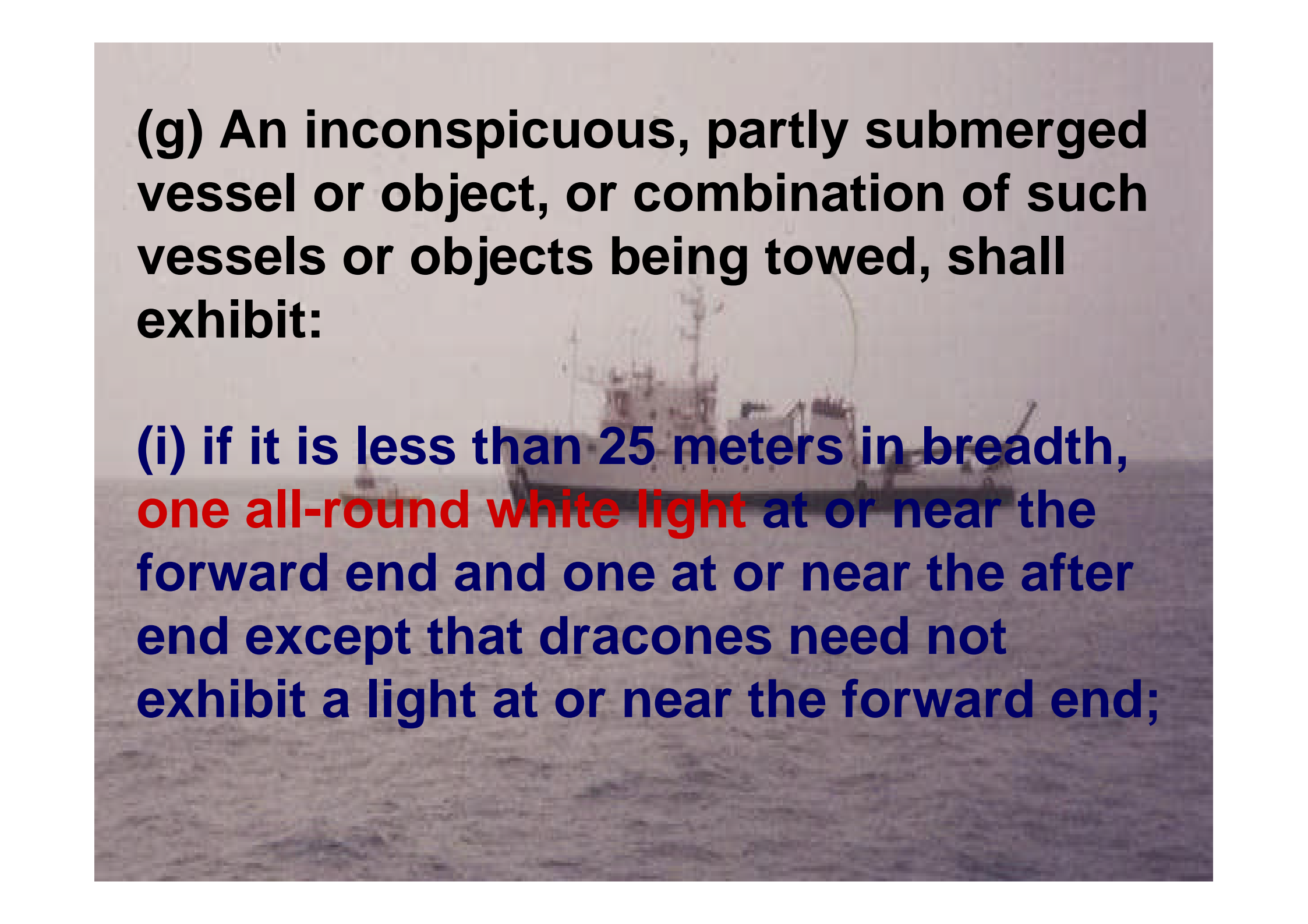
A large ship, possibly a cargo vessel, is visible in the background, partially obscured by the text. The ship is on the water, and its structure, including masts and rigging, is visible. The text is overlaid on the image, with the first part in black and the second part in blue and red.

(g) An inconspicuous, partly submerged vessel or object, or combination of such vessels or objects being towed, shall exhibit:

(i) if it is less than 25 meters in breadth, one all-round white light at or near the forward end and one at or near the after end except that dracones need not exhibit a light at or near the forward end;

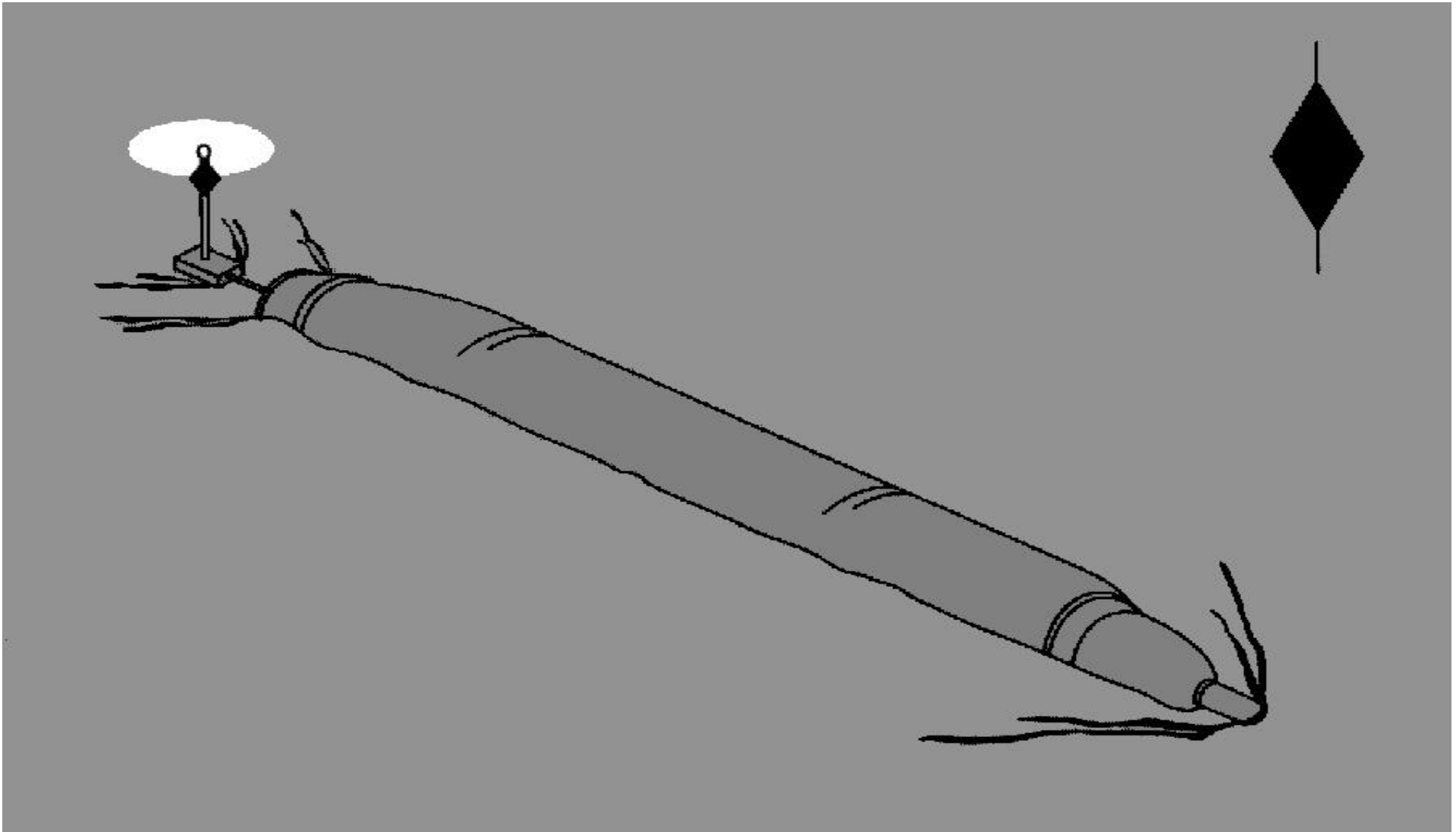

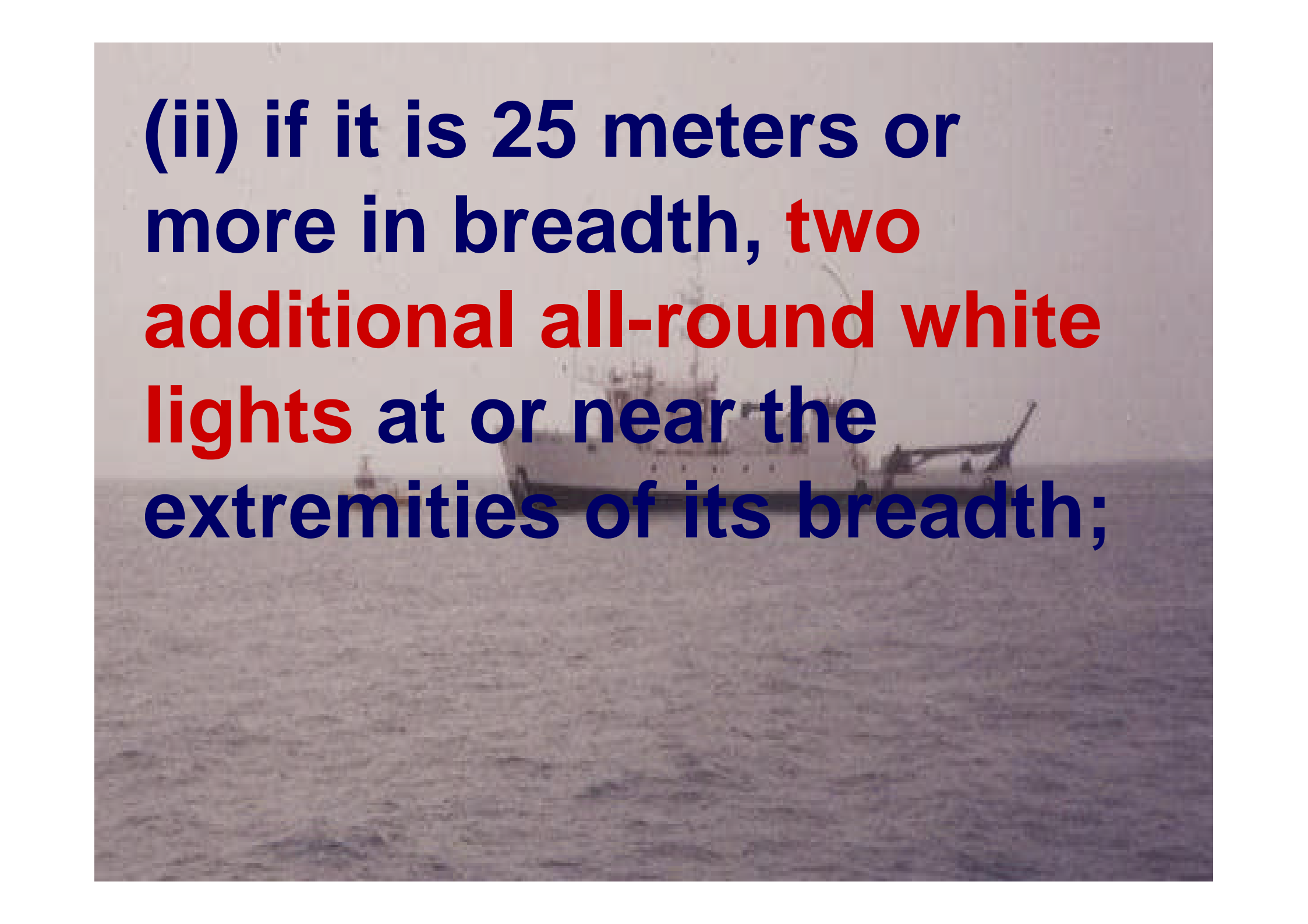

A large ship is visible in the background, sailing on a calm sea under a clear sky. The ship is a large vessel, possibly a cargo ship or a container ship, with a white hull and a dark superstructure. The text is overlaid on the image, with some words in red and some in blue.

(ii) if it is 25 meters or more in breadth, two additional all-round white lights at or near the extremities of its breadth;

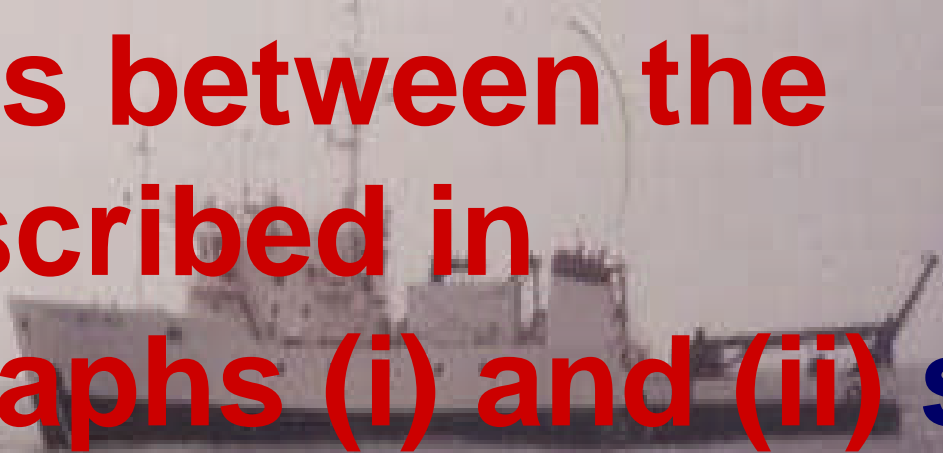

A large cargo ship is visible in the background, sailing on the open sea. The ship's navigation lights are visible, including a prominent red light on the left side of the ship's superstructure. The text is overlaid on this image.

(iii) if it exceeds 100 meters in length, additional all-round white lights between the lights prescribed in subparagraphs (i) and (ii) so that the distance between the lights shall not exceed 100 meters;

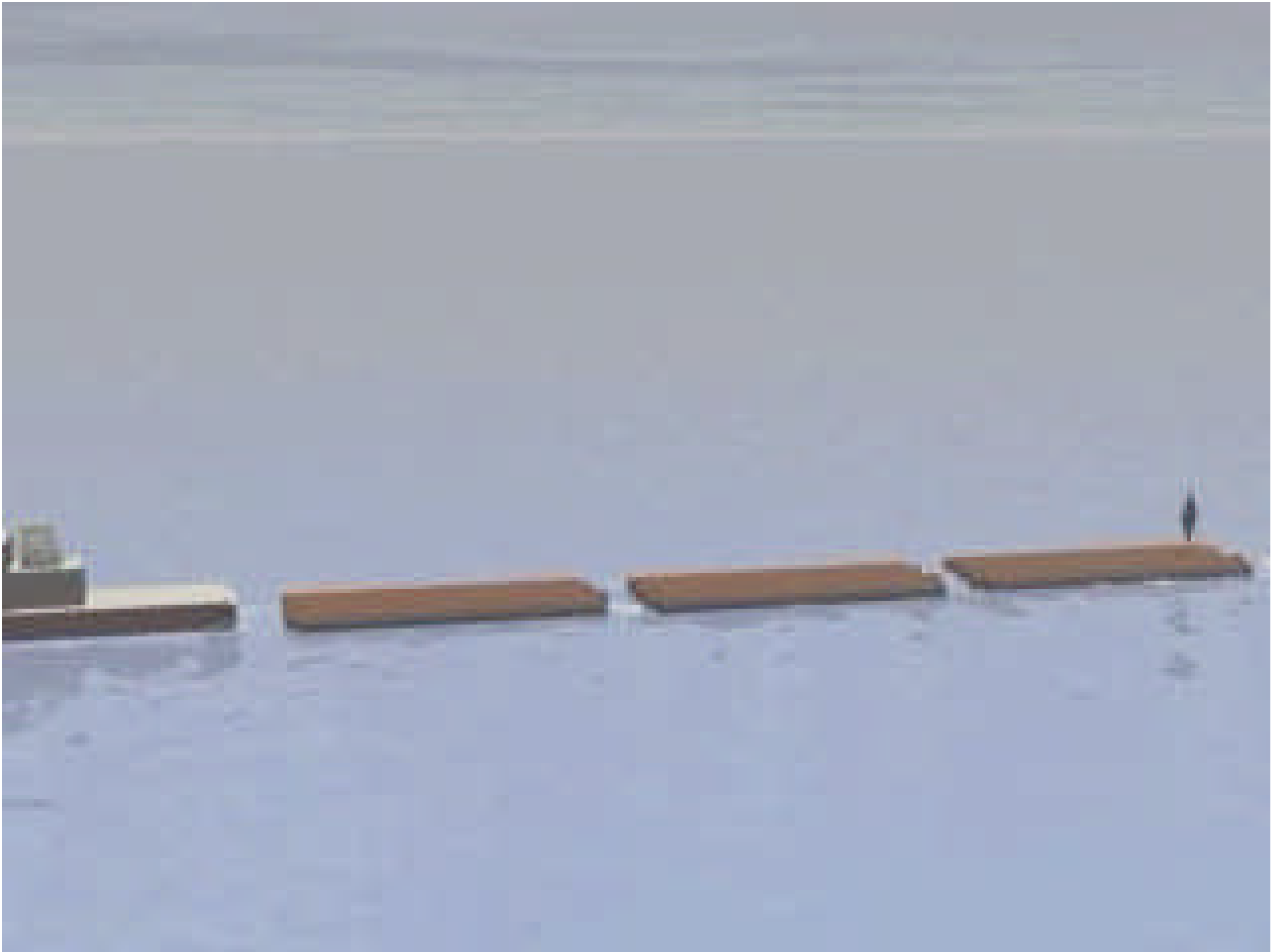

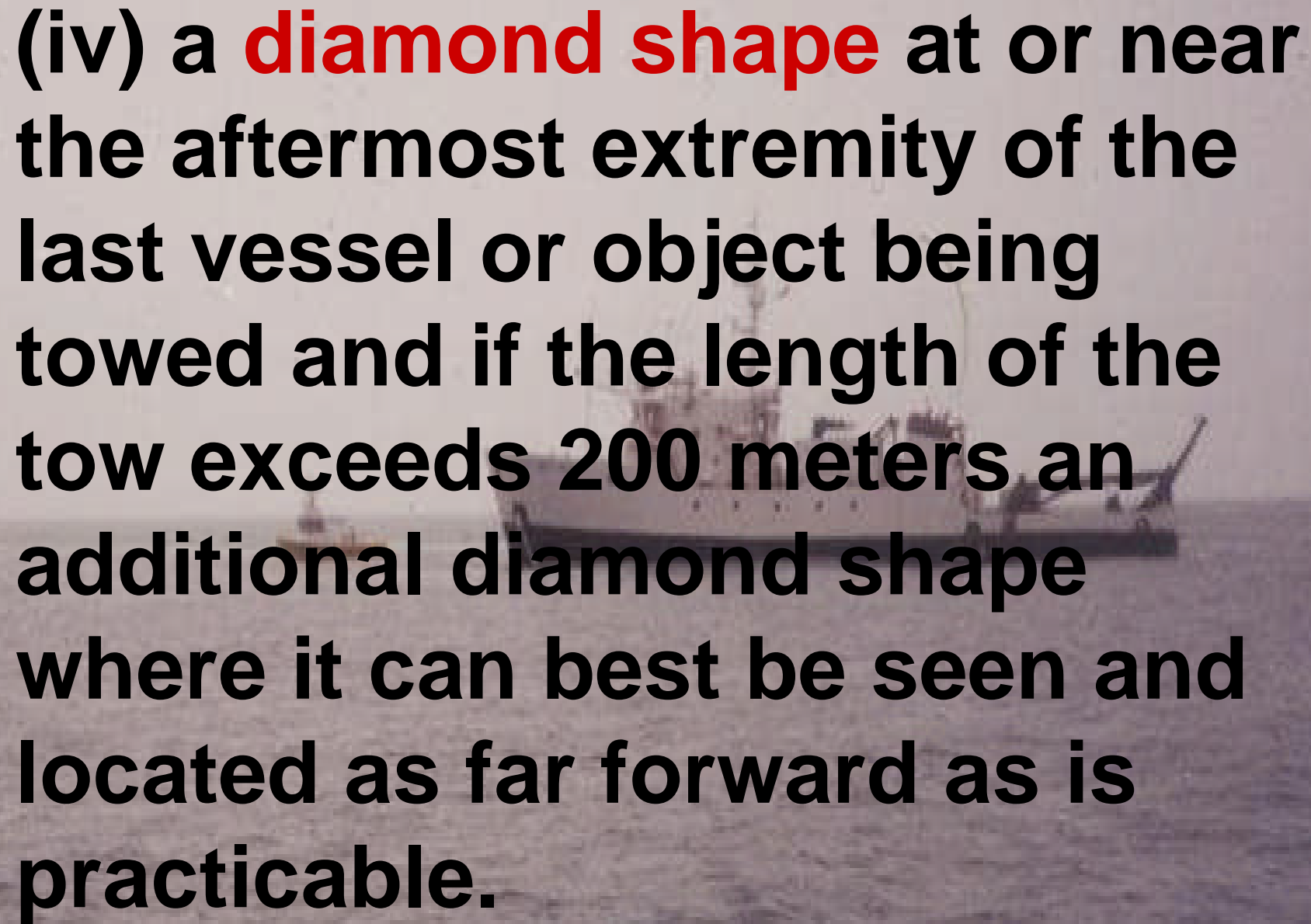
A large ship is visible in the background, sailing on the open sea. The ship has a prominent diamond-shaped light on its stern, which is the subject of the text. The text is overlaid on the image in a large, bold, black font, with the words "diamond shape" highlighted in red.

(iv) a diamond shape at or near the aftermost extremity of the last vessel or object being towed and if the length of the tow exceeds 200 meters an additional diamond shape where it can best be seen and located as far forward as is practicable.

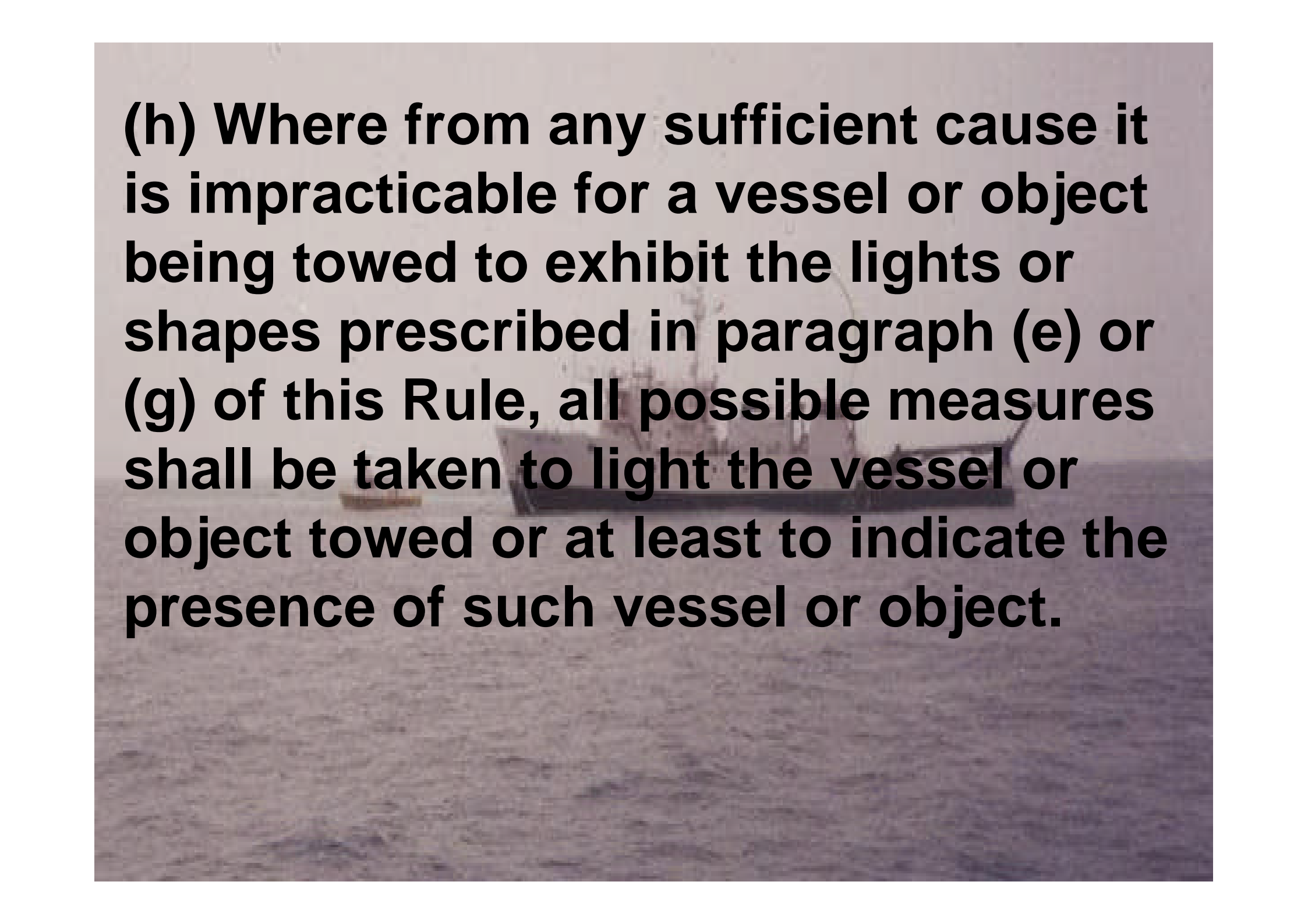

(h) Where from any sufficient cause it is impracticable for a vessel or object being towed to exhibit the lights or shapes prescribed in paragraph (e) or (g) of this Rule, all possible measures shall be taken to light the vessel or object towed or at least to indicate the presence of such vessel or object.

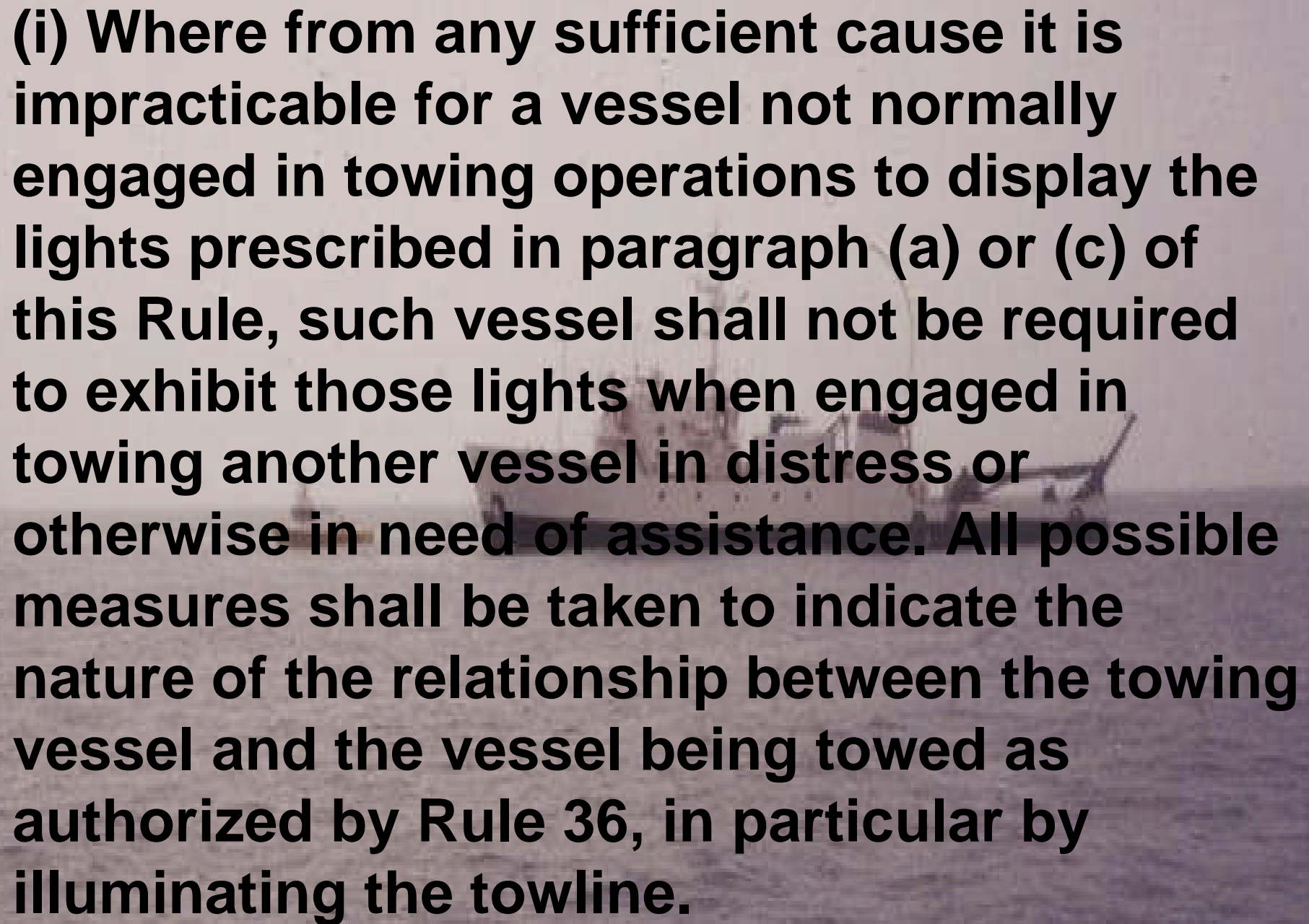
A large ship is towing a smaller vessel in distress on the open sea. The text is overlaid on this image.

(i) Where from any sufficient cause it is impracticable for a vessel not normally engaged in towing operations to display the lights prescribed in paragraph (a) or (c) of this Rule, such vessel shall not be required to exhibit those lights when engaged in towing another vessel in distress or otherwise in need of assistance. All possible measures shall be taken to indicate the nature of the relationship between the towing vessel and the vessel being towed as authorized by Rule 36, in particular by illuminating the towline.

End of Rule 2A

